

Michaels®

Embroidery Design
Sewing Information

Production Worksheet

Wilcom TrueSizer



Design: **Pirate Flag**

Title: **Pirate Flag**

Stitches: 4,829
 Height: 3.80 in
 Width: 2.43 in
 Colors: 7
 Colorway: Colorway 1
 Zoom: 1:1

Machine format: Tajima
 Color changes: 6
 Stops: 7
 Trims: 12
 Auto fabric: Pure Cotton
 Required stabilizer: Topping:
 Backing: Tear Away
 x 2
 Appliqués: 0
 Left: 30.9 mm
 Right: 30.9 mm
 Up: 48.3 mm
 Down: 48.3 mm
 EndX: 0.00 in
 EndY: 0.00 in
 Area: 9.25 in²
 Max stitch: 11.2 mm
 Min stitch: 0.3 mm
 Max jump: 6.9 mm
 Total thread: 94.89ft
 Total bobbin: 36.09ft

Stop Sequence:

#	#	Color	St.	Code	Name	Chart
1.	2	■	470	2		Wilcom
2.	13	■	253	13	Black	Wilcom
3.	6	■	912	6		Wilcom
4.	7	■	2,544	7		Wilcom
5.	3	□	338	3		Wilcom
6.	4	□	185	4		Wilcom
7.	5	■	125	5		Wilcom

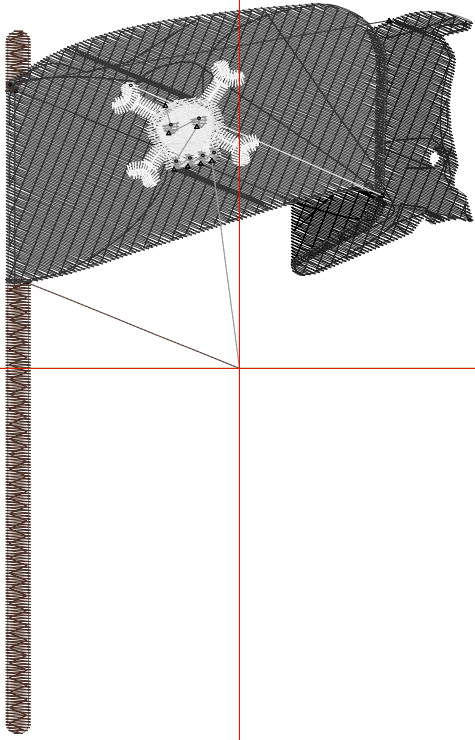

Color Film

Wilcom TrueSizer



Stitches: 4,829
Height: 3.80 in
Width: 2.43 in
Colors: 7
Colorway: Colorway 1
Zoom: 0.49

Design: **Pirate Flag**

Title: **Pirate Flag**

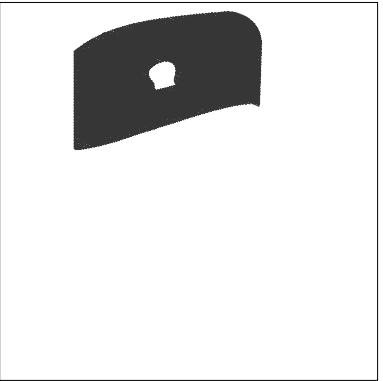
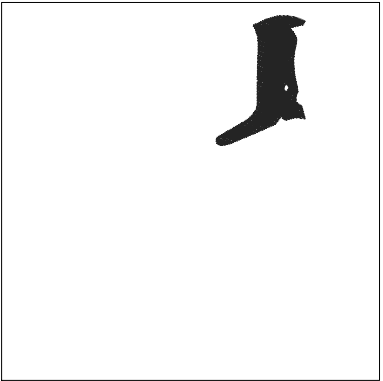
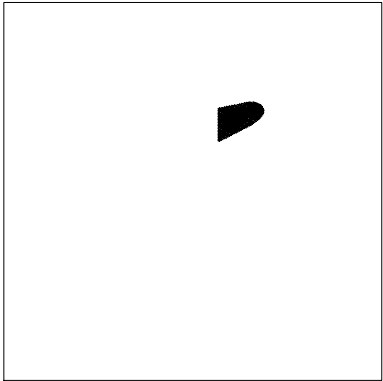
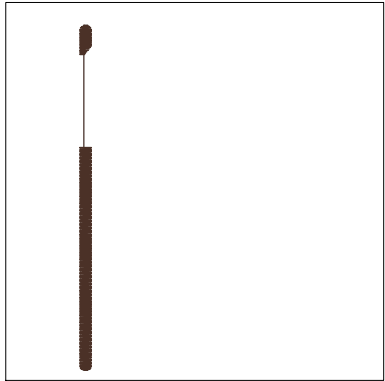

Stop #: 1
Code: 2
Name:
Chart: Wilcom
Stitches: 470
Thread used: 9.19ft

Stop #: 2
Code: 13
Name: Black
Chart: Wilcom
Stitches: 253
Thread used: 4.11ft

Stop #: 3
Code: 6
Name:
Chart: Wilcom
Stitches: 912
Thread used: 16.16ft

Stop #: 4
Code: 7
Name:
Chart: Wilcom
Stitches: 2,544
Thread used: 53.78ft

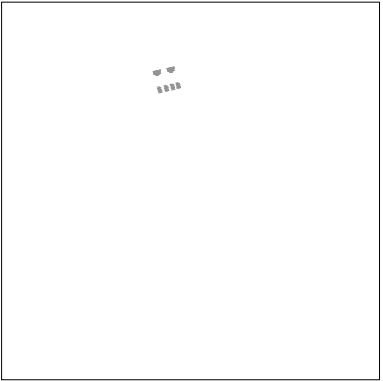
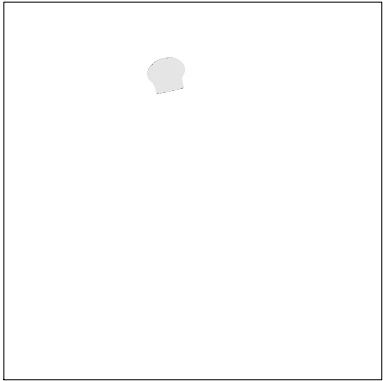
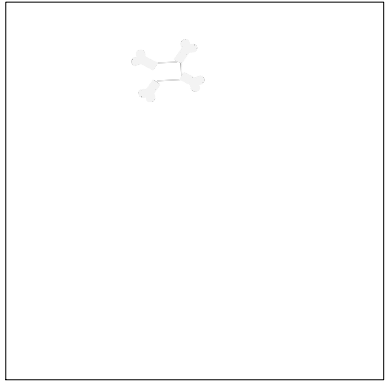

Stop #: 5
Code: 3
Name:
Chart: Wilcom
Stitches: 338
Thread used: 4.78ft

Stop #: 6
Code: 4
Name:
Chart: Wilcom
Stitches: 185
Thread used: 3.30ft

Stop #: 7
Code: 5
Name:
Chart: Wilcom
Stitches: 125
Thread used: 1.26ft