

Michaels®

Embroidery Design
Sewing Information

Production Worksheet

Wilcom TrueSizer



Stitches: 21,123
 Height: 3.82 in
 Width: 3.82 in
 Colors: 2
 Colorway: Colorway 1
 Zoom: 1:1

Design: **Retro Vinyl Disc with Player**

Title: **Retro Vinyl Disc with Player**

Machine format: Tajima
 Color changes: 2
 Stops: 3
 Trims: 13
 Auto fabric: Pure Cotton
 Required stabilizer: Topping:
 Backing: Tear Away
 x 2
 Appliqués: 0
 Left: 48.5 mm
 Right: 48.5 mm
 Up: 48.5 mm
 Down: 48.5 mm
 EndX: 0.00 in
 EndY: 0.00 in
 Area: 14.57 in²
 Max stitch: 6.9 mm
 Min stitch: 0.3 mm
 Max jump: 6.9 mm
 Total thread: 385.25ft
 Total bobbin: 145.58ft

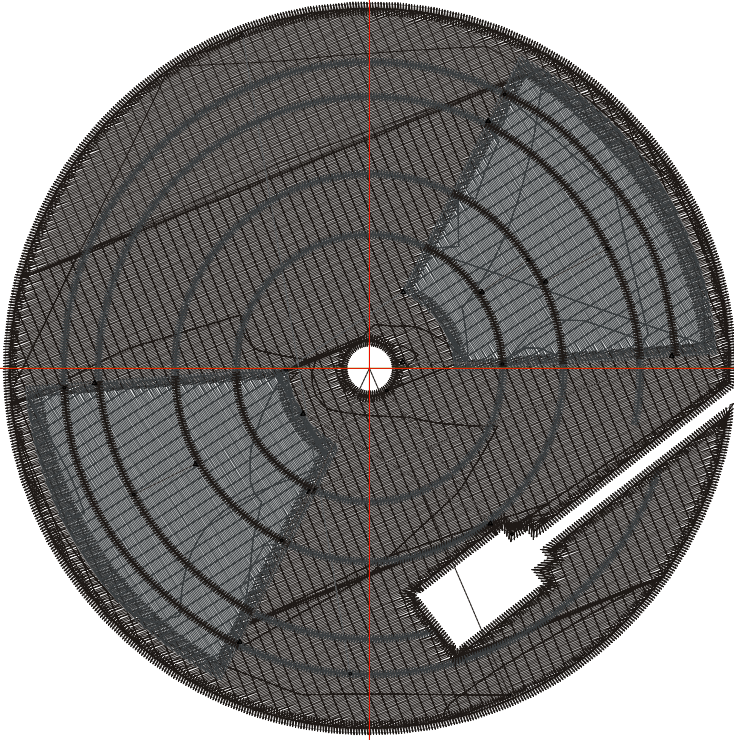

Stop Sequence:

| # | # | Color | St. | Code | Name | Chart |
|----|----|-------|-------|------|-------|--------|
| 1. | 13 | ■ | 9,588 | 13 | Black | Wilcom |
| 2. | 24 | ■ | 6,909 | 24 | | Wilcom |
| 3. | 13 | ■ | 4,624 | 13 | Black | Wilcom |

Color Film

Wilcom TrueSizer



Stitches: 21,123
Height: 3.82 in
Width: 3.82 in
Colors: 2
Colorway: Colorway 1
Zoom: 0.49

Design: **Retro Vinyl Disc with Player**

Title: **Retro Vinyl Disc with Player**

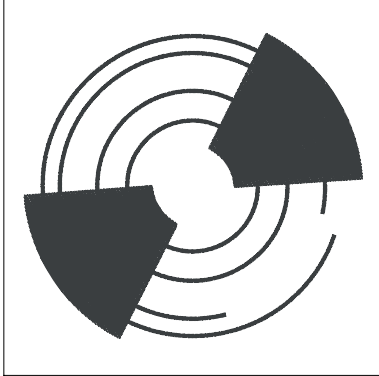
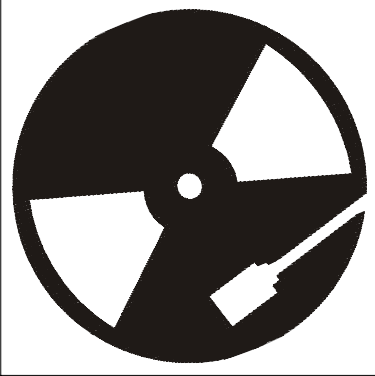

Stop #: 1
Code: 13
Name: Black
Chart: Wilcom
Stitches: 9,588
Thread used: 204.72ft

Stop #: 2
Code: 24
Name:
Chart: Wilcom
Stitches: 6,909
Thread used: 118.95ft

Stop #: 3
Code: 13
Name: Black
Chart: Wilcom
Stitches: 4,624
Thread used: 60.58ft