

Michaels®

Embroidery Design
Sewing Information

Production Worksheet

Wilcom TrueSizer



Design: **Waning Crescent**

Title: **Waning Crescent**

Stitches: 16,100
 Height: 3.80 in
 Width: 3.80 in
 Colors: 4
 Colorway: Colorway 1
 Zoom: 1:1

Machine format: Tajima
 Color changes: 3
 Stops: 4
 Trims: 10
 Auto fabric: Pure Cotton
 Required stabilizer: Topping:
 Backing: Tear Away x 2
 Appliqués: 0
 Left: 48.2 mm
 Right: 48.2 mm
 Up: 48.3 mm
 Down: 48.3 mm
 EndX: 0.00 in
 EndY: 0.00 in
 Area: 14.43 in²
 Max stitch: 6.8 mm
 Min stitch: 0.3 mm
 Max jump: 6.8 mm
 Total thread: 335.56ft
 Total bobbin: 135.47ft

Stop Sequence:

#	#	Color	St.	Code	Name	Chart
1.	41	☐	4,344	41	Chalk	Wilcom
2.	35	■	10,289	35	Murky Green	Wilcom
3.	42	☐	425	42	Pale Yellow	Wilcom
4.	13	■	1,040	13	Black	Wilcom

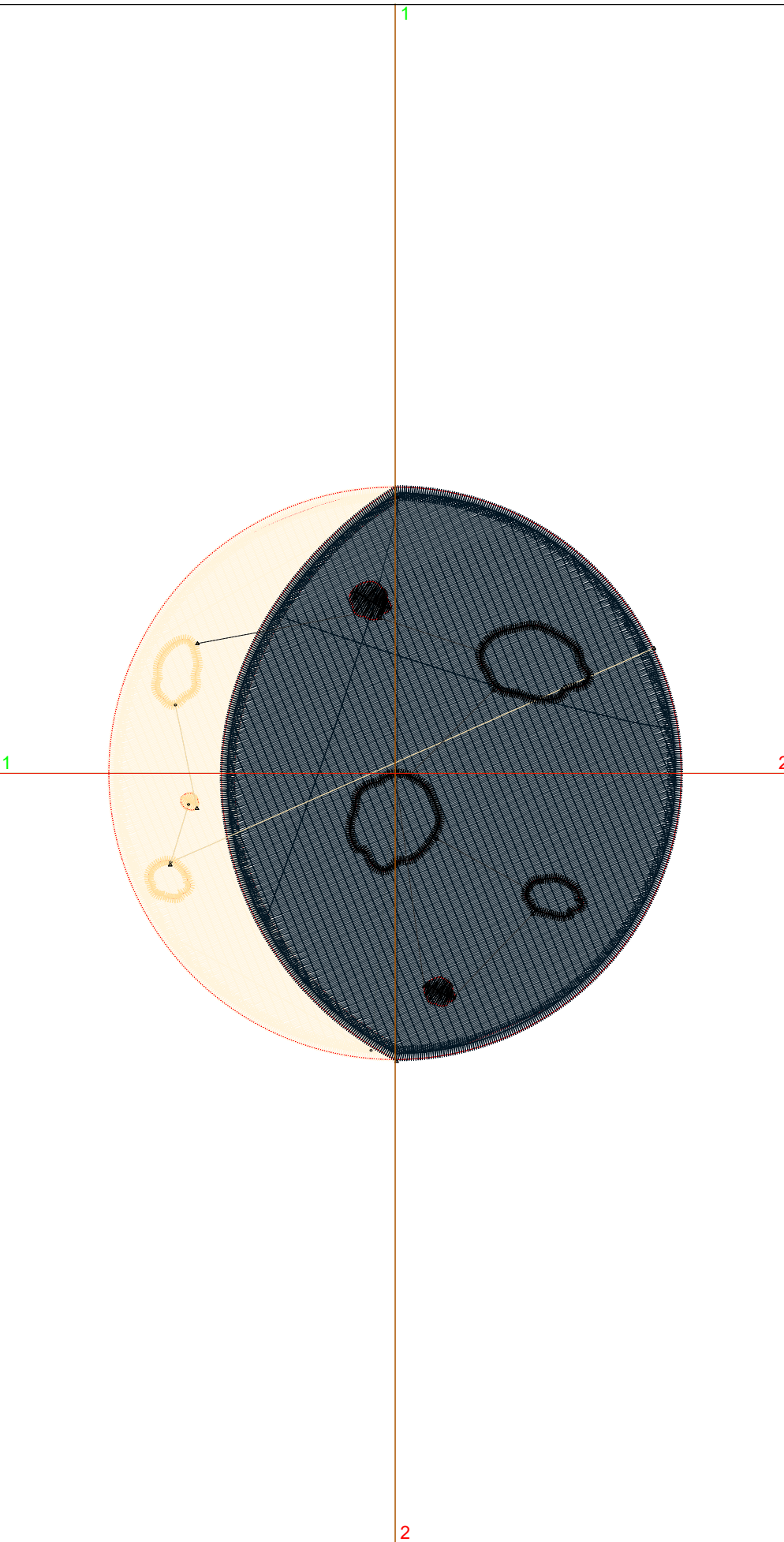

Color Film

Wilcom TrueSizer



Design: **Waning Crescent**

Title: **Waning Crescent**

Stitches: 16,100
Height: 3.80 in
Width: 3.80 in
Colors: 4
Colorway: Colorway 1
Zoom: 0.49

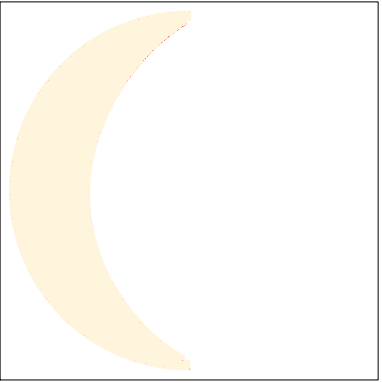

Stop #: 1
Code: 41
Name: Chalk
Chart: Wilcom
Stitches: 4,344
Thread used: 87.07ft

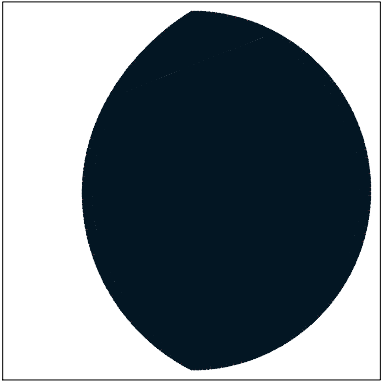

Stop #: 2
Code: 35
Name: Murky Green
Chart: Wilcom
Stitches: 10,289
Thread used: 227.19ft

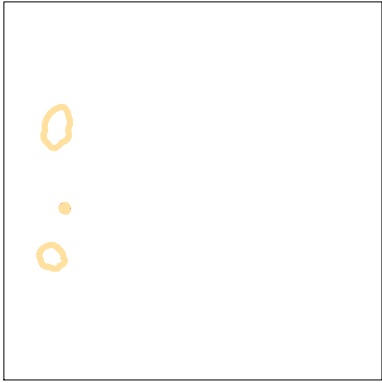

Stop #: 3
Code: 42
Name: Pale Yellow
Chart: Wilcom
Stitches: 425
Thread used: 5.44ft

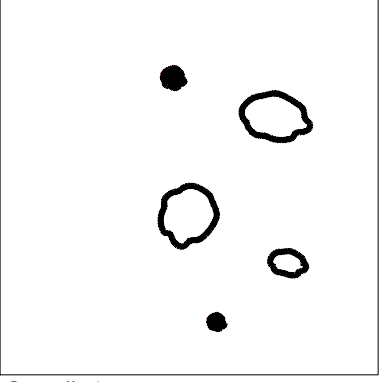

Stop #: 4
Code: 13
Name: Black
Chart: Wilcom
Stitches: 1,040
Thread used: 14.54ft