

Michaels®

Embroidery Design
Sewing Information

Production Worksheet

Wilcom TrueSizer



Design: **Sand Castle**

Title: **Sand Castle**

Stitches: 8,665
 Height: 3.81 in
 Width: 2.90 in
 Colors: 4
 Colorway: Madeira Classic 40
 Zoom: 1:1

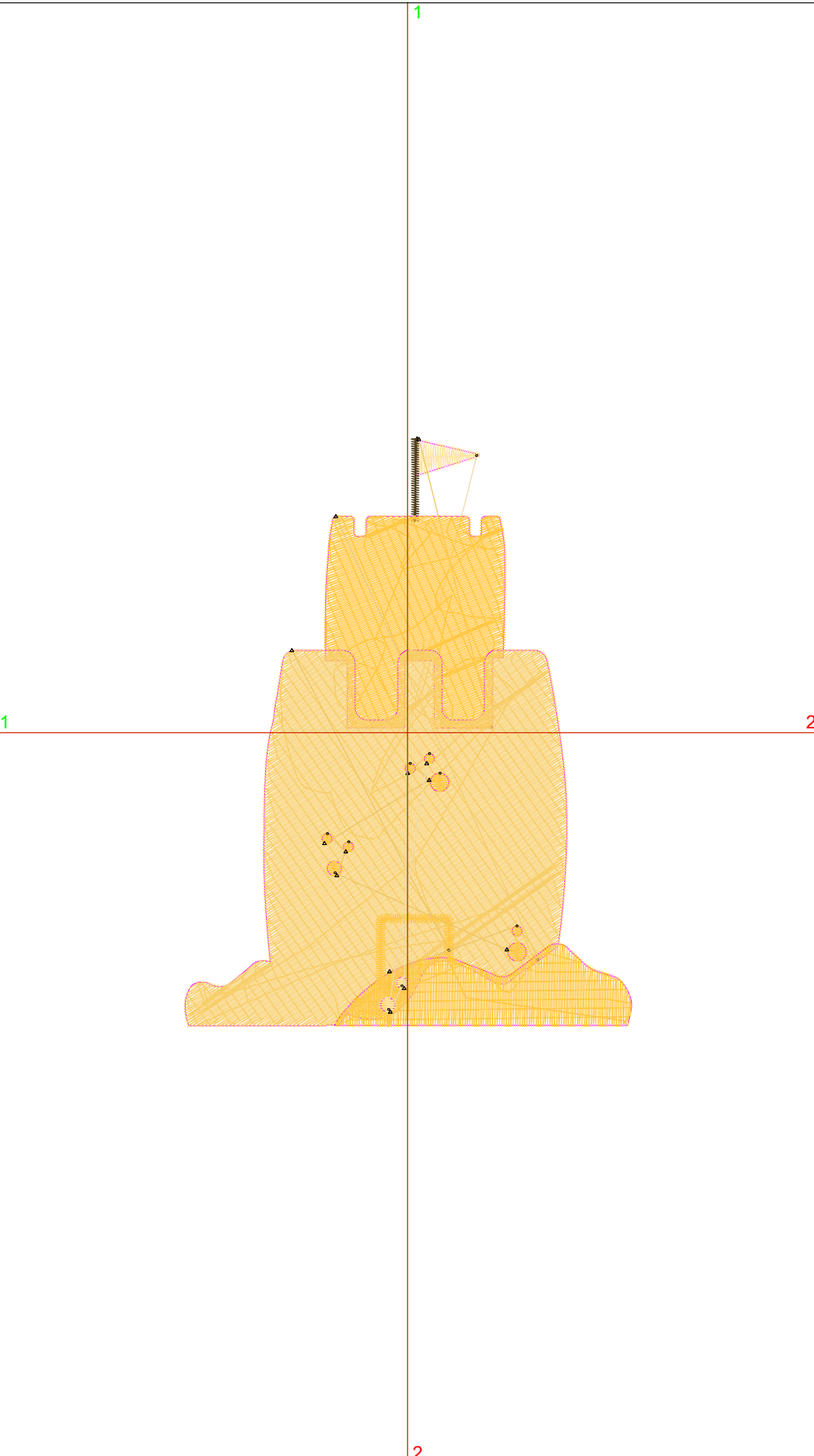

Machine format: Tajima
 Color changes: 5
 Stops: 6
 Trims: 14
 Auto fabric: Pure Cotton
 Required stabilizer: Topping:
 Backing: Tear Away x 2
 Appliqués: 0
 Left: 36.8 mm
 Right: 36.8 mm
 Up: 48.4 mm
 Down: 48.4 mm
 EndX: 0.00 in
 EndY: 0.00 in
 Area: 11.04 in²
 Max stitch: 6.8 mm
 Min stitch: 0.3 mm
 Max jump: 6.8 mm
 Total thread: 176.97ft
 Total bobbin: 70.01ft

Stop Sequence:

#	#	Color	St.	Code	Name	Chart
1.	4		92	1064	Madeira Classic 40	
2.	3		102	1146	Madeira Classic 40	
3.	1		1,918	1103	Madeira Classic 40	
4.	2		5,012	1934	Madeira Classic	
5.	1		1,475	1103	Madeira Classic 40	
6.	4		64	1064	Madeira Classic 40	

Color Film

Wilcom TrueSizer



Design: **Sand Castle**

Title: **Sand Castle**

Stitches: 8,665
Height: 3.81 in
Width: 2.90 in
Colors: 4
Colorway: Madeira Classic 40
Zoom: 0.49

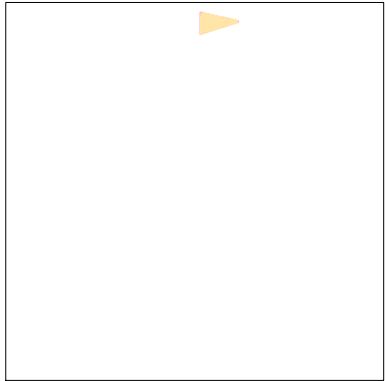

Stop #: 1
Code: 1064
Name:
Chart: Madeira Classic 40
Stitches: 92
Thread used: 1.71ft

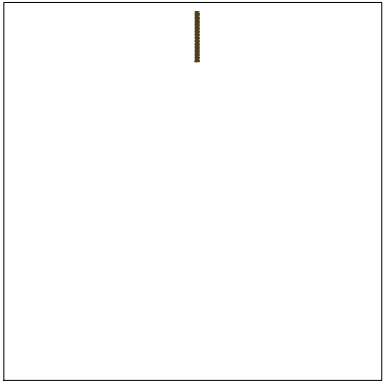

Stop #: 2
Code: 1146
Name:
Chart: Madeira Classic 40
Stitches: 102
Thread used: 1.24ft

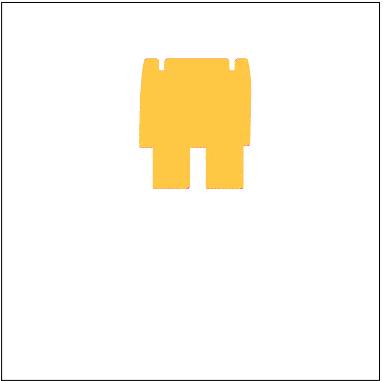

Stop #: 3
Code: 1103
Name:
Chart: Madeira Classic 40
Stitches: 1,918
Thread used: 38.23ft

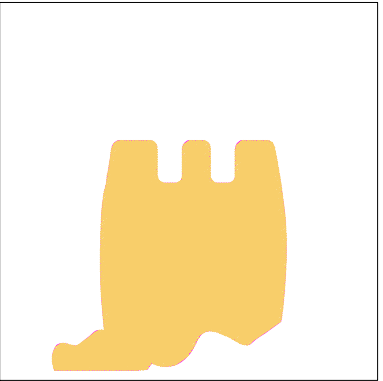

Stop #: 4
Code: 1934
Name:
Chart: Madeira Classic
Stitches: 5,012
Thread used: 108.15ft



Stop #: 5
Code: 1103
Name:
Chart: Madeira Classic 40
Stitches: 1,475
Thread used: 24.93ft

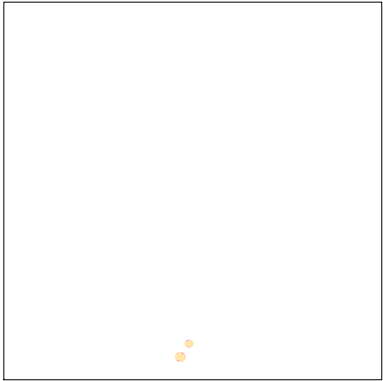

Stop #: 6
Code: 1064
Name:
Chart: Madeira Classic 40
Stitches: 64
Thread used: 0.72ft