

Michaels®

Embroidery Design
Sewing Information

Production Worksheet

Wilcom TrueSizer



Design: **Pool Ball and Cue**

Title: **Pool Ball and Cue**

Stitches: 4,275
 Height: 3.82 in
 Width: 3.30 in
 Colors: 4
 Colorway: Colorway 1
 Zoom: 1:1

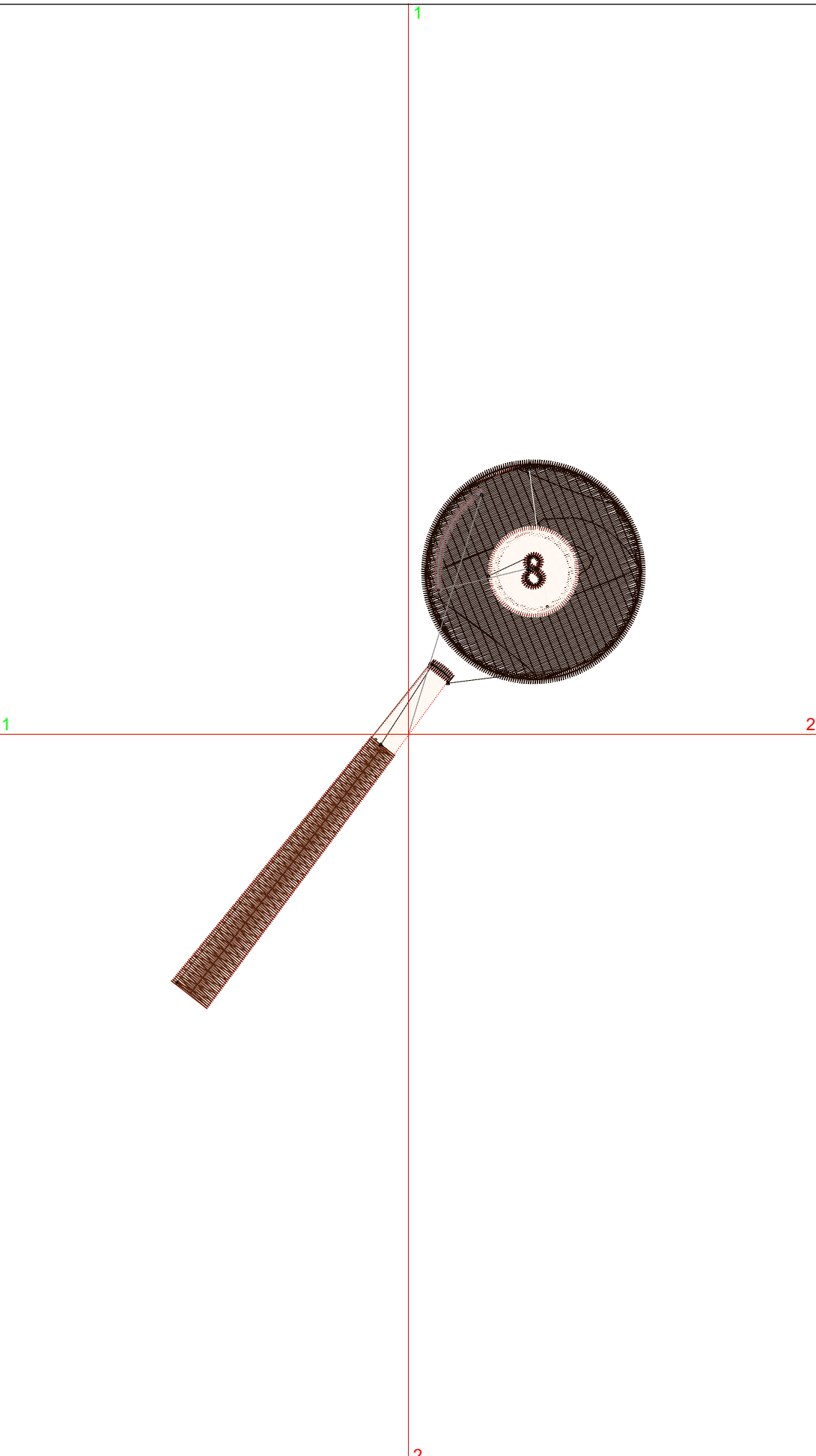

Machine format: Tajima
 Color changes: 5
 Stops: 6
 Trims: 7
 Auto fabric: Pure Cotton
 Required stabilizer: Topping:
 Backing: Tear Away
 x 2
 Appliqués: 0
 Left: 41.9 mm
 Right: 41.9 mm
 Up: 48.5 mm
 Down: 48.5 mm
 EndX: 0.00 in
 EndY: 0.00 in
 Area: 12.59 in²
 Max stitch: 7.4 mm
 Min stitch: 0.3 mm
 Max jump: 6.3 mm
 Total thread: 85.47ft
 Total bobbin: 32.86ft

Stop Sequence:

#	#	Color	St.	Code	Name	Chart
1.	15	☐	157	15	Wilcom	
2.	35	■	489	35	Wilcom	
3.	13	■	2,681	13	Wilcom	
4.	15	☐	650	15	Wilcom	
5.	13	■	145	13	Wilcom	
6.	14	■	151	14	Wilcom	

Color Film

Wilcom TrueSizer



Design: **Pool Ball and Cue**

Title: **Pool Ball and Cue**

Stitches: 4,275
Height: 3.82 in
Width: 3.30 in
Colors: 4
Colorway: Colorway 1
Zoom: 0.49

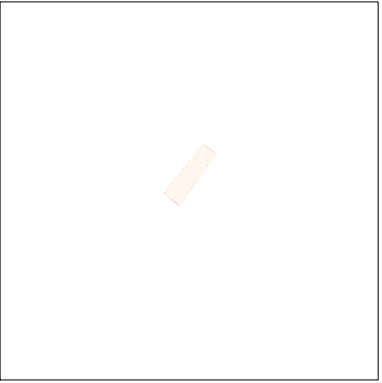

Stop #: 1
Code: 15
Name:
Chart: Wilcom
Stitches: 157
Thread used: 3.70ft

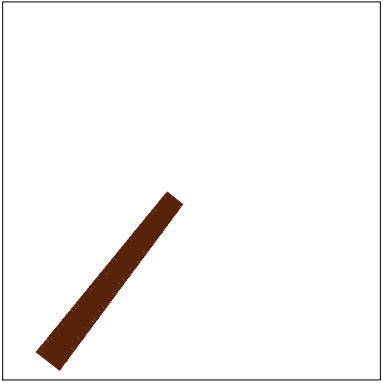

Stop #: 2
Code: 35
Name:
Chart: Wilcom
Stitches: 489
Thread used: 14.84ft

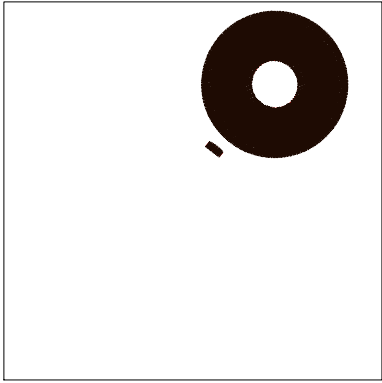

Stop #: 3
Code: 13
Name:
Chart: Wilcom
Stitches: 2,681
Thread used: 50.59ft

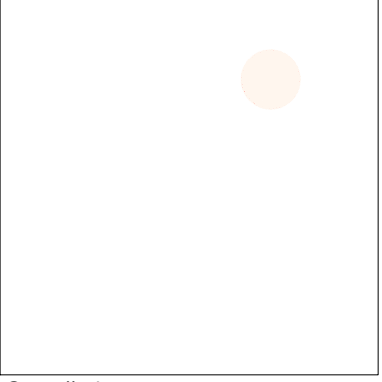

Stop #: 4
Code: 15
Name:
Chart: Wilcom
Stitches: 650
Thread used: 10.83ft

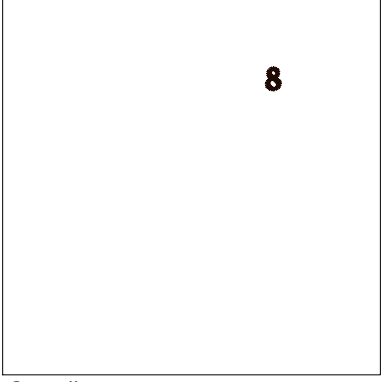

Stop #: 5
Code: 13
Name:
Chart: Wilcom
Stitches: 145
Thread used: 1.67ft

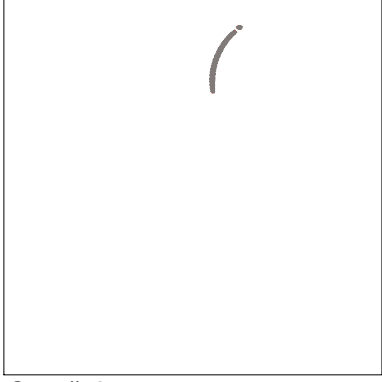

Stop #: 6
Code: 14
Name:
Chart: Wilcom
Stitches: 151
Thread used: 1.86ft