

Michaels®

Embroidery Design
Sewing Information

Production Worksheet

Wilcom TrueSizer



Design: **Magic book**

Title: **Magic book**

Stitches: 23,580
 Height: 3.82 in
 Width: 2.89 in
 Colors: 4
 Colorway: Colorway 1
 Zoom: 1:1

Machine format: Tajima
 Color changes: 4
 Stops: 5
 Trims: 26
 Auto fabric: Pure Cotton
 Required stabilizer: Topping:
 Backing: Tear Away x 2
 Appliqués: 0
 Left: 36.8 mm
 Right: 36.8 mm
 Up: 48.5 mm
 Down: 48.5 mm
 EndX: 0.00 in
 EndY: 0.00 in
 Area: 11.05 in²
 Max stitch: 10.6 mm
 Min stitch: 0.3 mm
 Max jump: 7.0 mm
 Total thread: 428.34ft
 Total bobbin: 161.17ft

Stop Sequence:

#	#	Color	St.	Code	Name	Chart
1.	2	■	9,301	13	Black	Wilcom
2.	3	■	6,944	14	Grey	Wilcom
3.	1	■	4,171	4		Wilcom
4.	4	■	715	53	Faded Pink	Wilcom
5.	2	■	2,447	13	Black	Wilcom

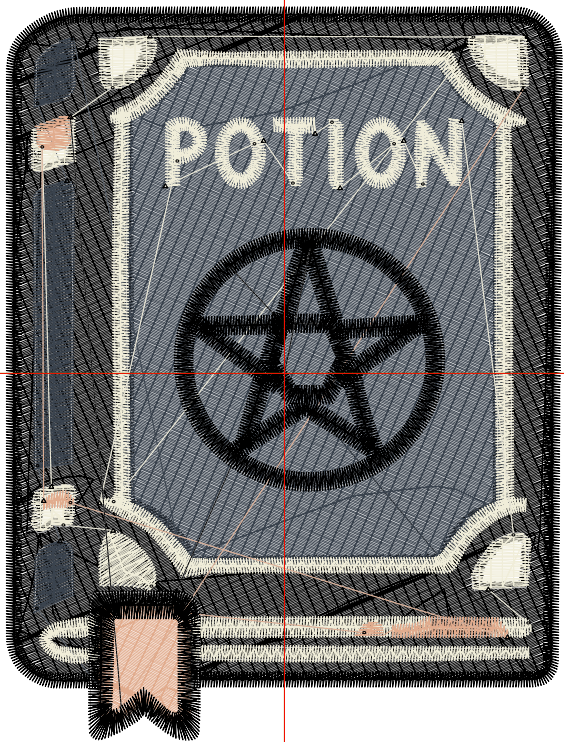

Color Film

Wilcom TrueSizer



Design: **Magic book**

Title: **Magic book**

Stitches: 23,580
Height: 3.82 in
Width: 2.89 in
Colors: 4
Colorway: Colorway 1
Zoom: 0.49

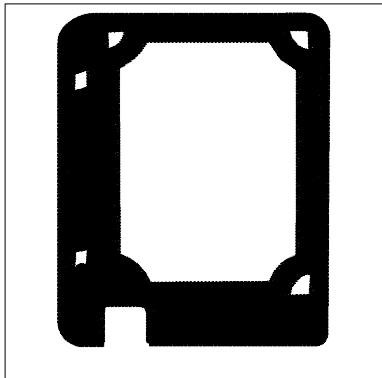

Stop #: 1
Code: 13
Name: Black
Chart: Wilcom
Stitches: 9,301
Thread used: 168.02ft

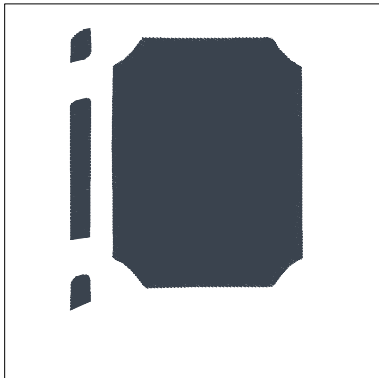

Stop #: 2
Code: 14
Name: Grey
Chart: Wilcom
Stitches: 6,944
Thread used: 141.50ft

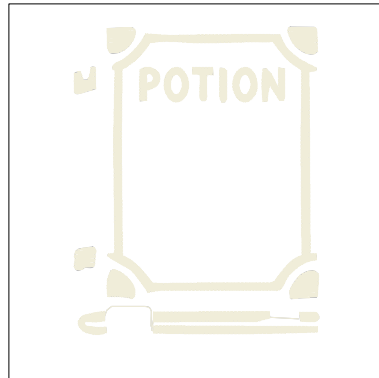

Stop #: 3
Code: 4
Name:
Chart: Wilcom
Stitches: 4,171
Thread used: 62.81ft

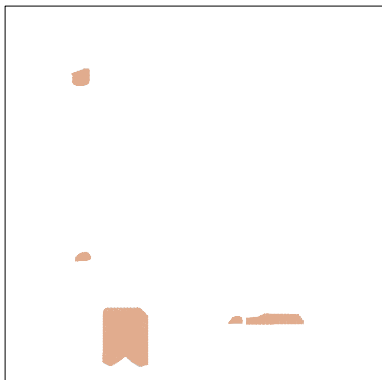

Stop #: 4
Code: 53
Name: Faded Pink
Chart: Wilcom
Stitches: 715
Thread used: 11.97ft

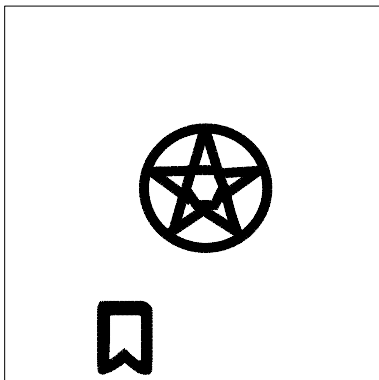

Stop #: 5
Code: 13
Name: Black
Chart: Wilcom
Stitches: 2,447
Thread used: 42.39ft