

Michaels®

Embroidery Design
Sewing Information

Production Worksheet

Wilcom TrueSizer



Design: **Unicycle**

Title: **Unicycle**

Stitches: 3,082
 Height: 3.81 in
 Width: 1.75 in
 Colors: 3
 Colorway: Colorway 1
 Zoom: 1:1

Machine format: Tajima
 Color changes: 2
 Stops: 3
 Trims: 4
 Auto fabric: Custom Fabric
 Required stabilizer: Topping:
 Backing: Tear Away x 2
 Appliqués: 0
 Left: 22.4 mm
 Right: 22.2 mm
 Up: 48.1 mm
 Down: 48.8 mm
 EndX: 0.00 in
 EndY: 0.00 in
 Area: 6.69 in²
 Max stitch: 6.9 mm
 Min stitch: 0.5 mm
 Max jump: 6.9 mm
 Total thread: 60.15ft
 Total bobbin: 23.08ft

Stop Sequence:

#	#	Color	St.	Code	Name	Chart
1.	12	■	1,673	Black	Madeira Classic 1000	
2.	10	■	427		Madeira Classic 1278	
3.	18	■	980		Madeira Classic 1125	

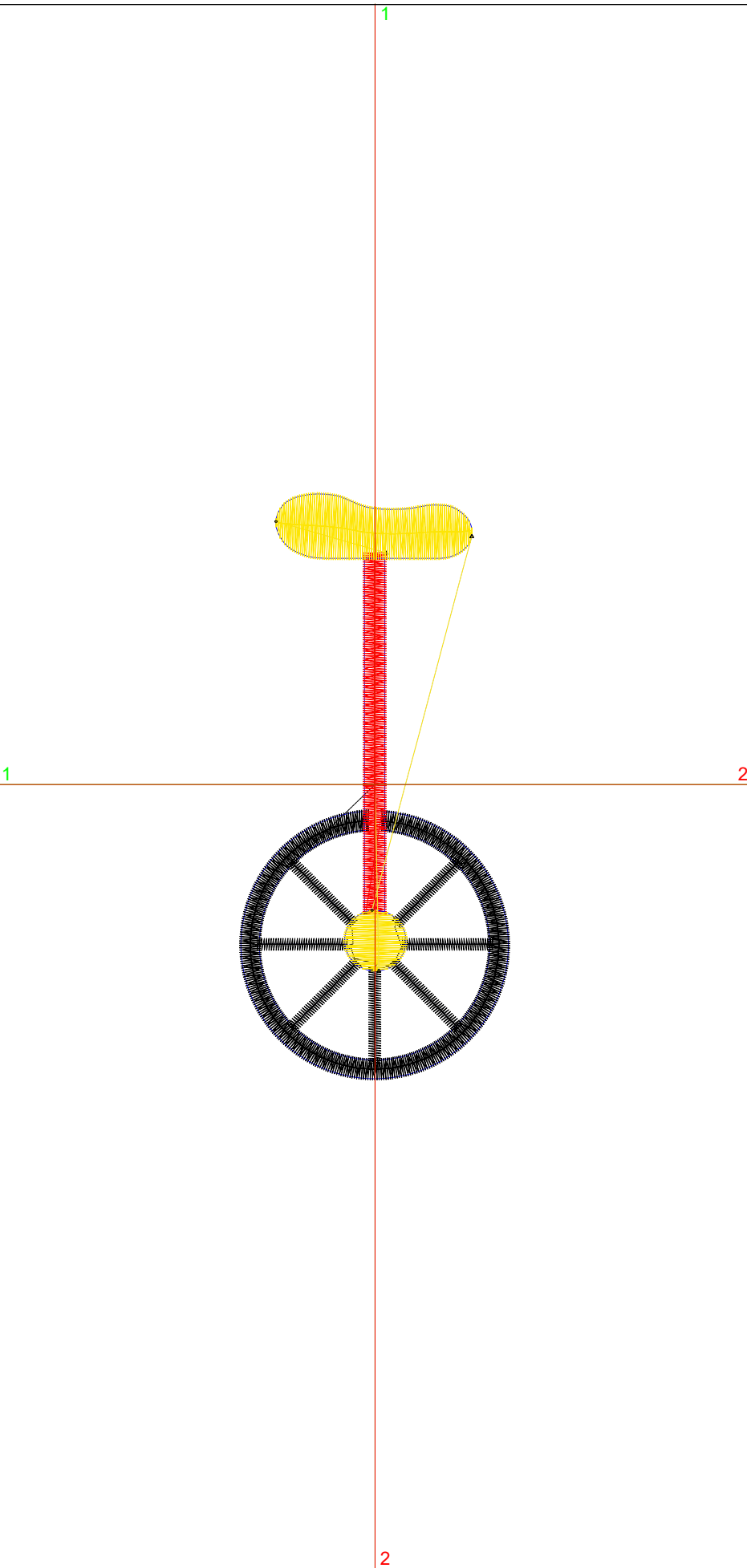

Color Film

Wilcom TrueSizer



Design: **Unicycle**

Title: **Unicycle**

Stitches: 3,082

Height: 3.81 in

Width: 1.75 in

Colors: 3

Colorway: Colorway 1

Zoom: 0.49

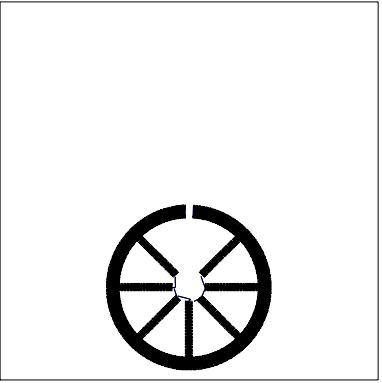

Stop #: 1
Code: Black
Name:
Chart: Madeira Classic 1000
Stitches: 1,673
Thread used: 31.56ft

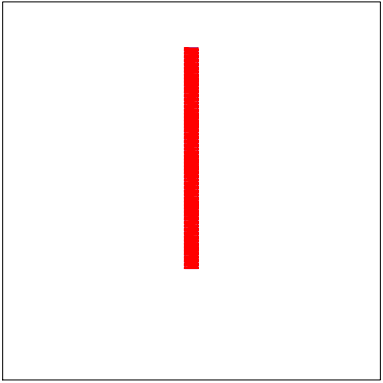

Stop #: 2
Code:
Name:
Chart: Madeira Classic 1278
Stitches: 427
Thread used: 9.60ft

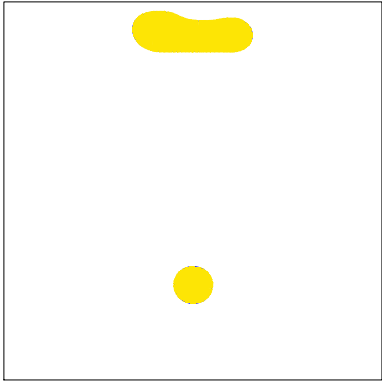

Stop #: 3
Code:
Name:
Chart: Madeira Classic 1125
Stitches: 980
Thread used: 17.99ft